

NOTE:

1. WHEN USING METAL STUDS, ALL GUIDE RAIL BLOCKING AND MACHINE SUPPORT BLOCKING, SHALL BE PRESSURE TREATED LUMBER.

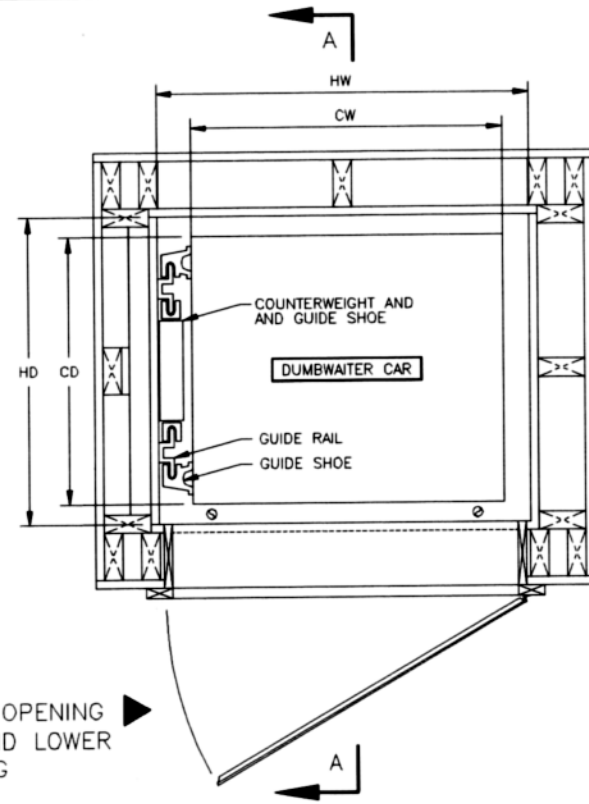

**MILLER
MANUFACTURING
INCORPORATED**
165 Cascade Court
Rohnert Park, CA 94928-1683



ALL DIMENSIONS ARE FINISH(TOP NUMBERS ARE METRIC)

RESIDENTIAL MODEL	DIMENSIONS	(HW) HOISTWAY WIDTH	(HD) HOISTWAY DEPTH	CAR DIMENSIONS			CAPACITY KILOS (lbs)	(E) EQUIPMENT SPACE	(H) TOP FLOOR TO CEILING	LIFT RATIO
				(CW) WIDTH	(CD) DEPTH	(CH) INSIDE HEIGHT				
R28F	METRIC	81	68.5	71	60	91.4	64	88	256.5	4.4
	INCHES	(32")	(27")	(28")	(24")	(36")	(100)	(35")	(8'-5")	